

# HANTS® FIRE PROTECTION

UL OS&Y GATE VALVE

HGO-200FF

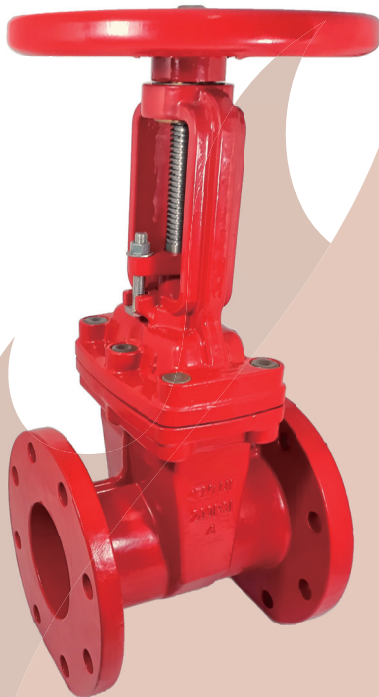

## HGO-200FF

**Valve Standard:**  
Conforms to AWWA C515

**Working pressure:**  
200PSI / 300PSI

**Flanged Ends:**  
ANSI B16.1 Class125/150/250,  
EN1092-2 PN10/PN16/PN25

**Size:** 2 1/2"(DN65) to 12"(DN300)

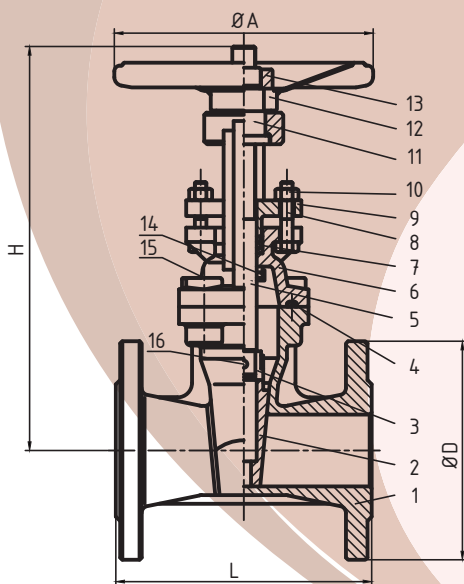

No.	Parts Name	Material
1	Body	Ductile Iron
2	Disc	Ductile Iron+EPDM
3	Connecting Part	ASTM A148
4	Sealing Pad	EPDM
5	Stem	SS304
6	Cap	Ductile Iron
7	Sealing Kits	PTFE
8	Bolt	Steel
9	Platen	Ductile Iron
10	Nut	SS304
11	Rotating Nut	ASTM B148
12	Handwheel	ASTM A1045
13	Lock Net	ASTM A1045
14	Flat Key	Steel
15	Countersunk Head Bolt	Steel
16	Cylinder Pin	Steel

Size(mm)	2"	2.5"	3"	4"	5"	6"	8"	10"	12"
DN	50	65	80	100	125	150	200	250	300
L	178	191	203	229	254	267	292	330	356
H	280	310	370	428	532	590	735	908	1150
øA	180	220	250	280	300	350	380	450	450
øD	152	178	190	229	254	279	343	406	483